

Technical Subject:

Development of the Electrical and Mechanical Characteristic Measurement System for DNA

Corresponding Applicant: **Takao Okada (Research Institute of Biomolecule Metrology, Co., Ltd.)**

Co researcher:

Takashi Morii (RIBM), Norihiko Matsushita (RIBM), Rika Mizuno (RIBM), Hiroataka Haruta (RIBM), Ryoji Hirota (RIBM), Hiroaki Sugasawa (RIBM), Tadashi Terada (RIBM)

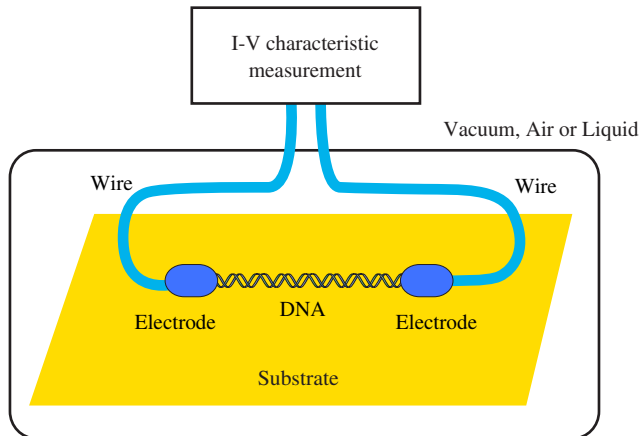

Measurement System of Electrical Properties:
A well-defined contact has to be used to obtain a reproducible result. We will do so.

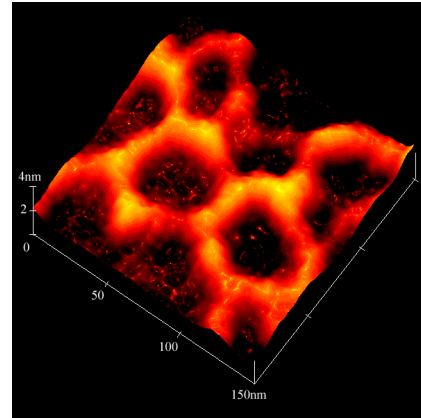

Hexagon DNA synthesized by our designer DNA technology developed in cooperation with Prof. Hayashi of Kyusyu Univ.

Goal :

Our target is to establish stable and reliable methods for the measurement of electrical and mechanical properties of DNA molecules so as to promise the next-generation device utilizing DNA.

Method / Approach :

For electrical properties,

- 1) Fabricating electrodes on an insulating substrate using the existing LSI technology.
- 2) Connecting DNA to the electrodes. The dimensions of the contact area and the geometrical shape are controlled by utilizing the self-organization of DNA. For this purpose our designer DNA technology must be of great use.
- 3) Observing the vicinity of the interface between DNA and the electrode by Scanning Probe Microscope.
- 4) Applying voltage to DNA and measuring current-voltage characteristics.

For mechanical properties,

- 1) Fixing one edge of the DNA to an appropriate substrate
- 2) Connecting the other edge of DNA to cantilever of Molecular Force Microscope
- 3) Pulling DNA and measuring Young's modulus

Introduction / Position in the session :

In the present semiconductor industry, a degree of integration and a line width are getting close to the limits. Hence the DNA device is got interested as one of the potential candidates to advance beyond the limits. The electrical property of DNA has been studied by several research groups. However the results are not completely identical and they are partly conflictive each other. It is pointed out that the discrepancy is caused by the fact that a stable and reliable method for the electric connection to DNA has not been established yet. So as to clarify the electrical property of the contact portion, we propose to use the well-defined contact which will be realized by controlling the interface between DNA and the electrode. The establishment of the stable methods for the electrical and mechanical characteristic measurement of DNA will make a great contribution to the realization of DNA devices.

Call for collaboration :

We would like to collaborate with everyone who is interested in our experiments, especially those who has an idea to evaluate a magnetic property of DNA.